

PRODUCT BROCHURE

SMARTEMP[®]
IN COMFORT



Adjustable Helical Swirl Diffuser

HSC-AD

DESCRIPTION

The SMARTEMP® Adjustable Helical Swirl Diffuser, type HSC-AD, produces highly inductive swirl discharge of the supply air, diffusing the swirling air stream with adjustable horizontal-to-vertical discharge direction and strong mixing characteristics into the space. High levels of draught-free cooling and efficient heating from elevated discharge heights to floor level are achieved from the patent pending design.

The cambered leading edges of the twenty off-set radial vanes reduce both the sound power level and pressure drop, improving aural comfort and saving fan energy. The geometric twist of the helical vane tips provides increased downward penetration when heating and reduces the minimum permissible airflow rate of the diffuser when cooling. The pressure drop of the diffuser is substantially constant across the full range of airflow direction adjustment, ensuring stable HVAC system operation regardless of discharge direction.

The HSC-AD diffuser may be flush mounted in a ceiling or freely suspended (ie no Coanda attachment to the ceiling required). The recommended discharge height is 2.5 to 15 m.

The maximum recommended differential between supply air and room air is -13 K when discharging horizontally in cooling mode, and up to +15 K when discharging downwards in heating mode, depending on airflow rate and discharge height. Discharge direction adjustment may be manual, electric or by thermal wax element (ie no controls or wiring required). The HSC-AD swirl vanes form a flush surface with the surrounding flat diffuser face, which may be square (available up to neck size DN500 only) or round (figures 1 & 2).

The diffuser is made of powder coated sheet-metal and is available with nominal neck diameters of 250 mm, 355 mm, 500 mm and 710 mm.

For a given total pressure, the diffuser airflow rate approximately halves for each reduction in neck size. For smaller airflow steps, each diffuser size is available with an optional reducer (visible in figure 2) and reduced guide ring to decrease the airflow rate by approximately 30% at a given pressure. For a further 30% reduction in airflow rate the next neck size down should be selected without reducer.

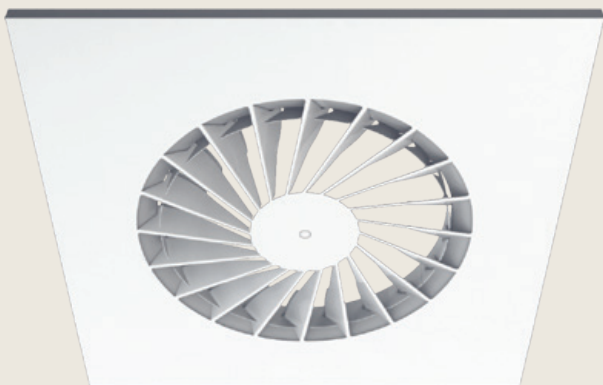

Figure 1

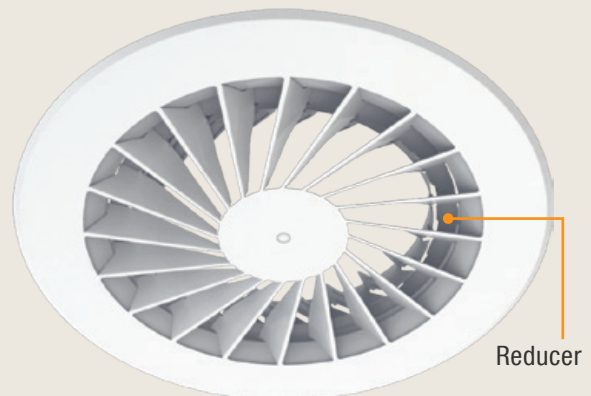

Figure 2

Mode of Operation

The highly inductive swirl discharge from the HSC-AD intensely entrains secondary air from the room into the supply air stream, thereby strongly increasing the supply air stream mass flow rate, and produces rapid discharge velocity decay. As a result, at any given airflow rate, the HSC-AD swirl diffuser is suitable both for long throws (due to the high mass flow rate of the supply air stream) as well as short throws (due to the air stream's low velocity) making it an extremely adaptable diffuser. Strong dilution of the supply air stream provides rapid supply air stream temperature equalisation – and hence density equalisation – with room air, preventing cold air dumping. Low velocity air motion with uniform temperature distribution is achieved, producing high levels of thermal comfort (no cold and draughty or hot and stagnant spots).

The HSC-AD swirl diffuser's patent pending adjustable discharge direction design allows stepless discharge direction adjustment between horizontal and vertical and achieves high induction swirl discharge even in heating mode. This ensures low velocity and gust-free operation when heating, directing the strongly diluted, gently swirling supply air

stream downwards over considerable discharge heights. This achieves uniform temperature distribution of the warm, low velocity supply air into the occupied space. The constant pressure characteristics of the diffuser across the full range of discharge direction adjustment ensure not only that airflow rates, and hence system airflow balancing, remain constant but that fan surging is avoided regardless of discharge direction adjustment, contributing to precise thermostatic control and stable HVAC system operation year round.

Discharge direction may be adjusted manually, electrically or thermally. The latter is self-acting via a thermal element mechanism that includes maximum heating bias adjustment from 20°C to 35°C (figure 3). The electrical and thermal kits (figure 4) are interchangeable attachments to the optional base module, which, in their absence, offers manual adjustment through the diffuser face. The diffuser without the base module offers manual adjustment only through the diffuser face.

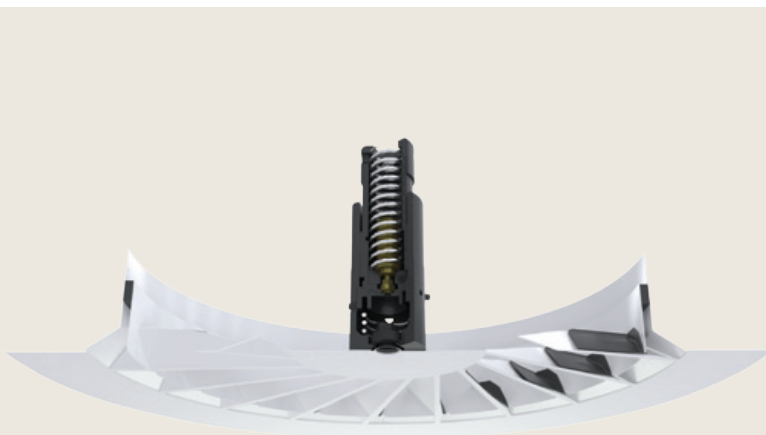

Figure 3

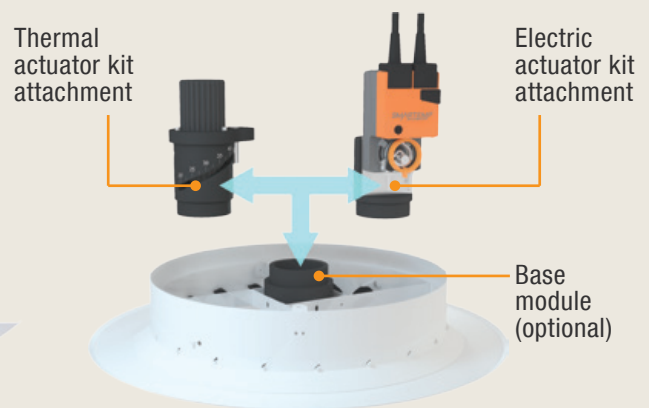
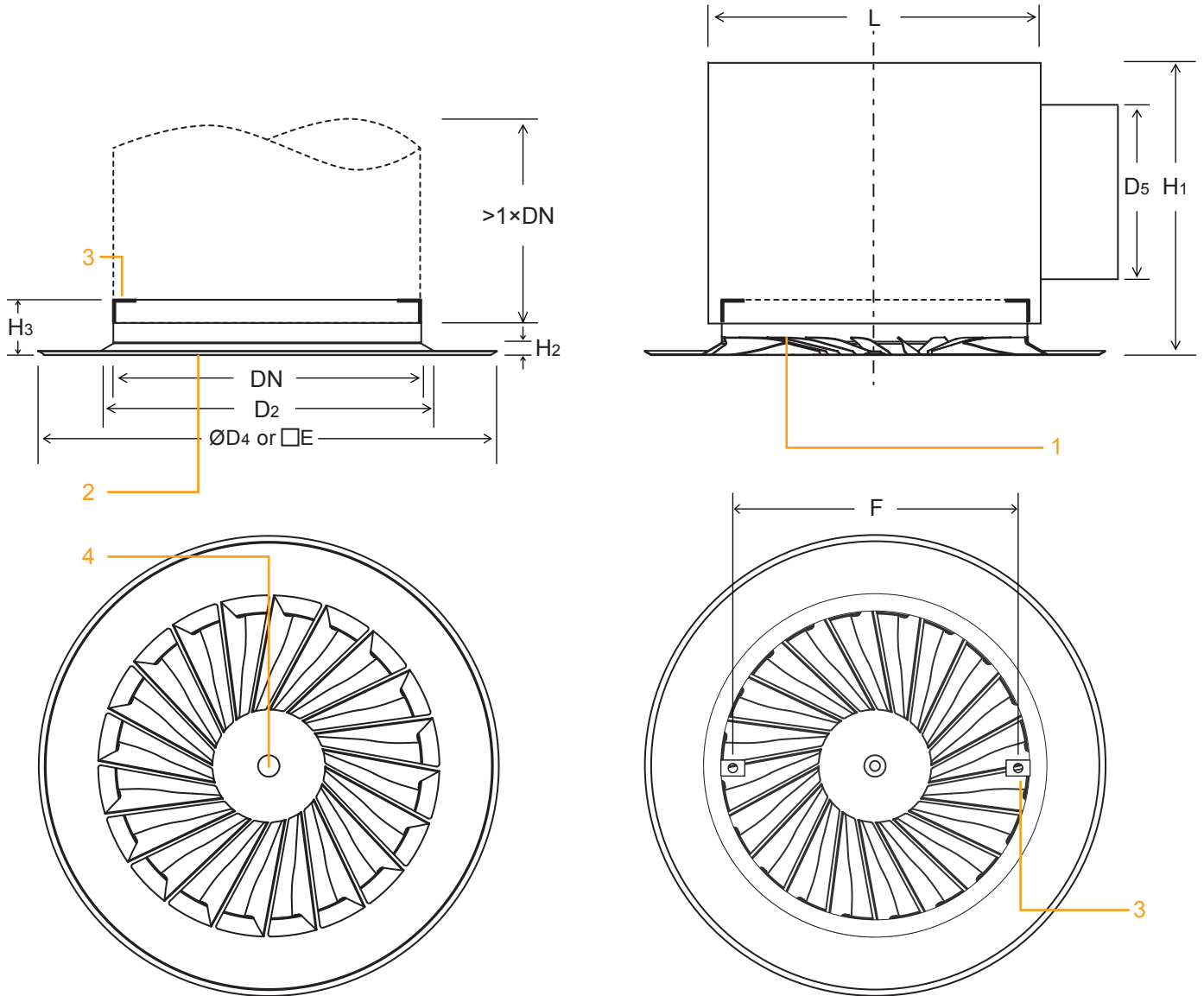

Figure 4

TECHNICAL DATA

- 1 - HSC-AD-C_-K - circular face, connection box
- 2 - HSC-AD-C_-R - circular face, round duct connection
- 3 - Fixing bracket with 6mm hole
- 4 - Cap



DIMENSIONS

	D₂	D₄	E	D₅	L	H₁	H₂	H₃	F
DN250	270	375*	295	249	425	400	14	60	200
DN355	395	530*	445,595,603	354	495	550	20	80	320
DN500	560	750*	595,603	499	695	690	28	100	465
DN710	790	1000	-	-	-	-	32	240	440

Products supplied may differ slightly from those described in this technical brochure due to on-going product development.
 * Diameter updated 01/2018

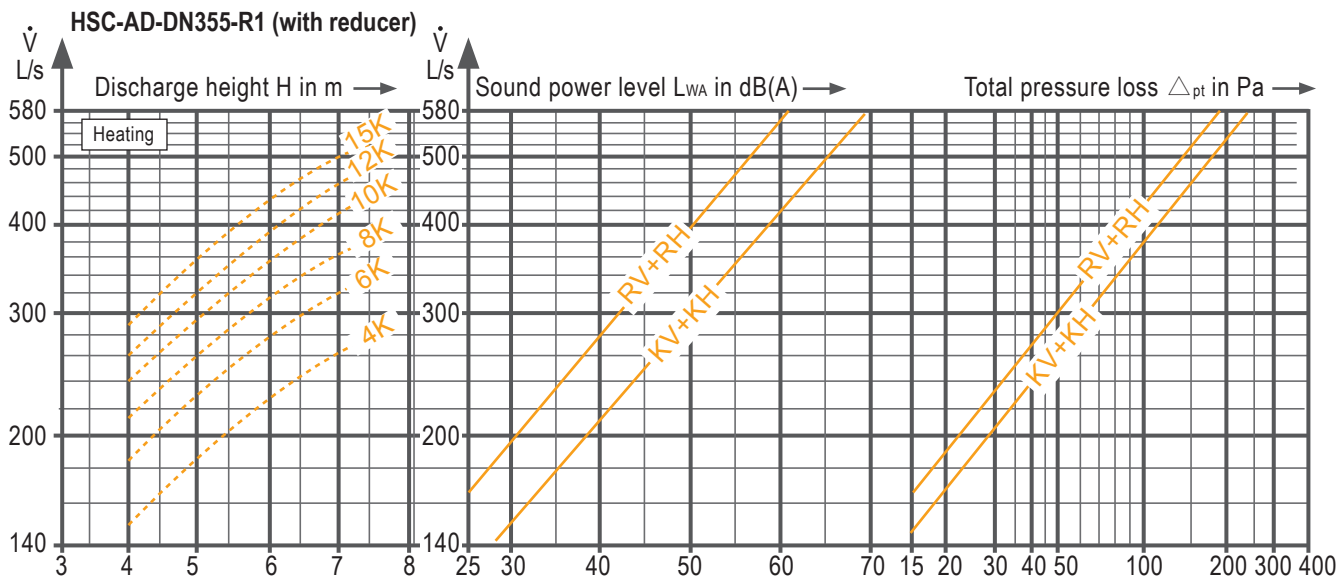
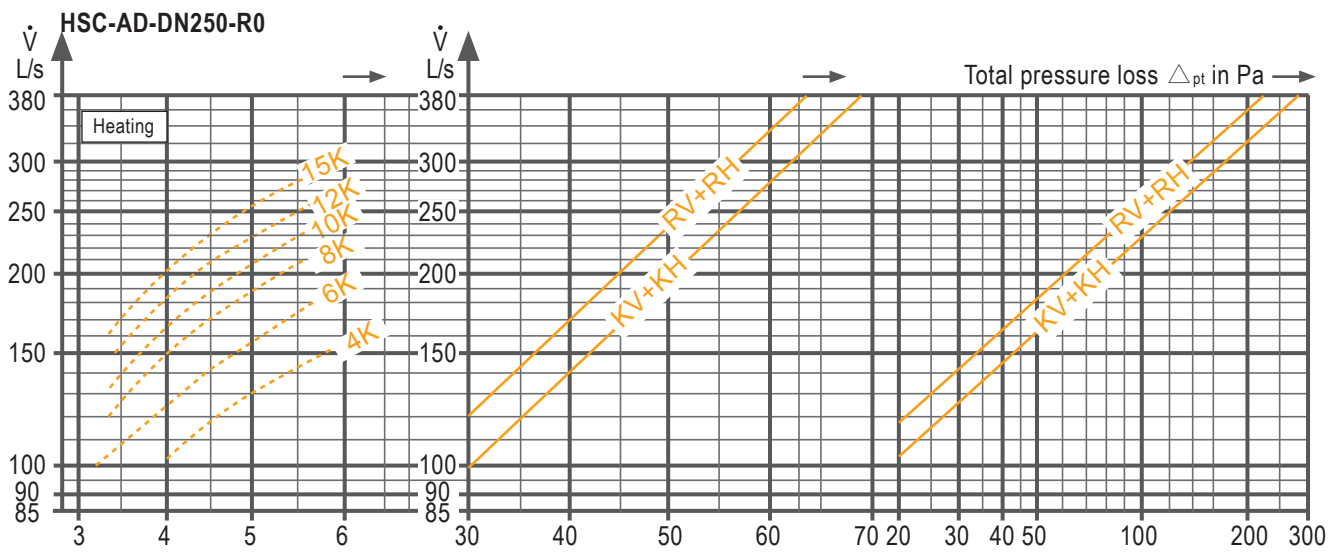
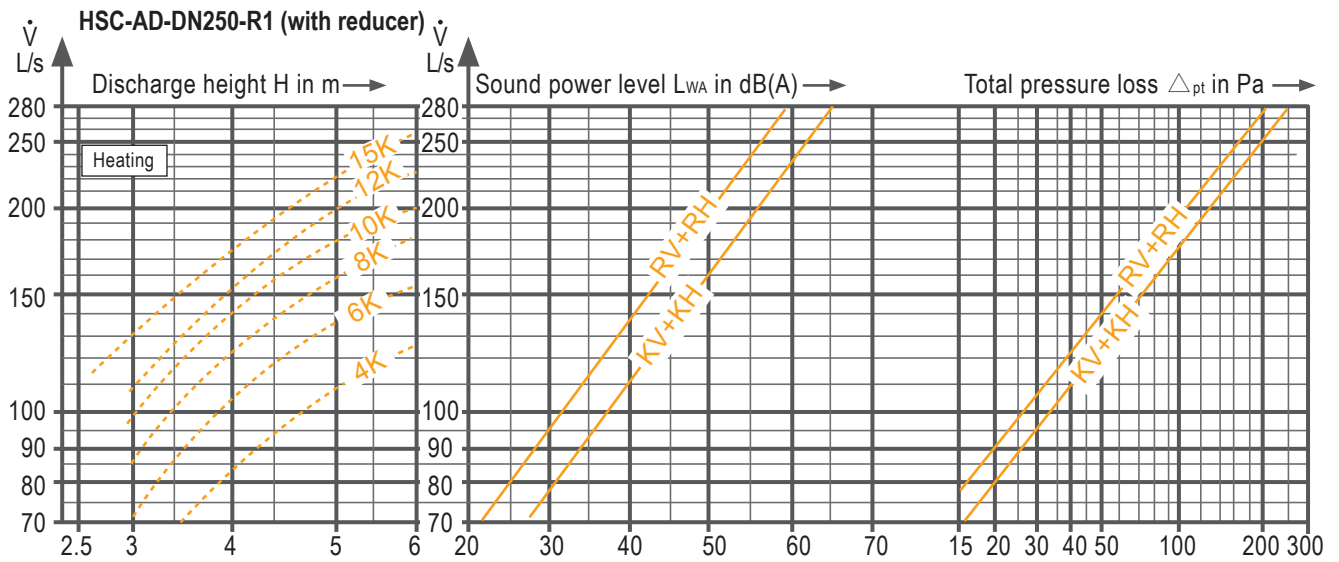

Notes:

R = Round duct connection
K = Connection box

H = Horizontal discharge
V = Vertical discharge

Without acoustic lining the sound power level of the connection box is up to 2 dB(A) higher.

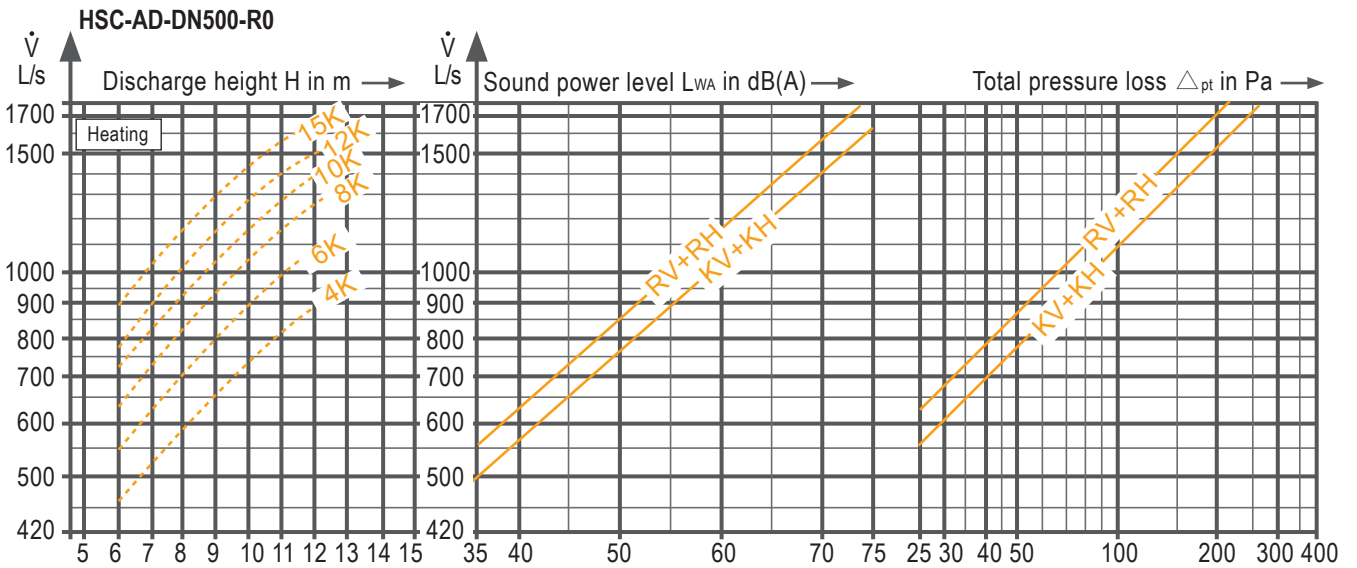
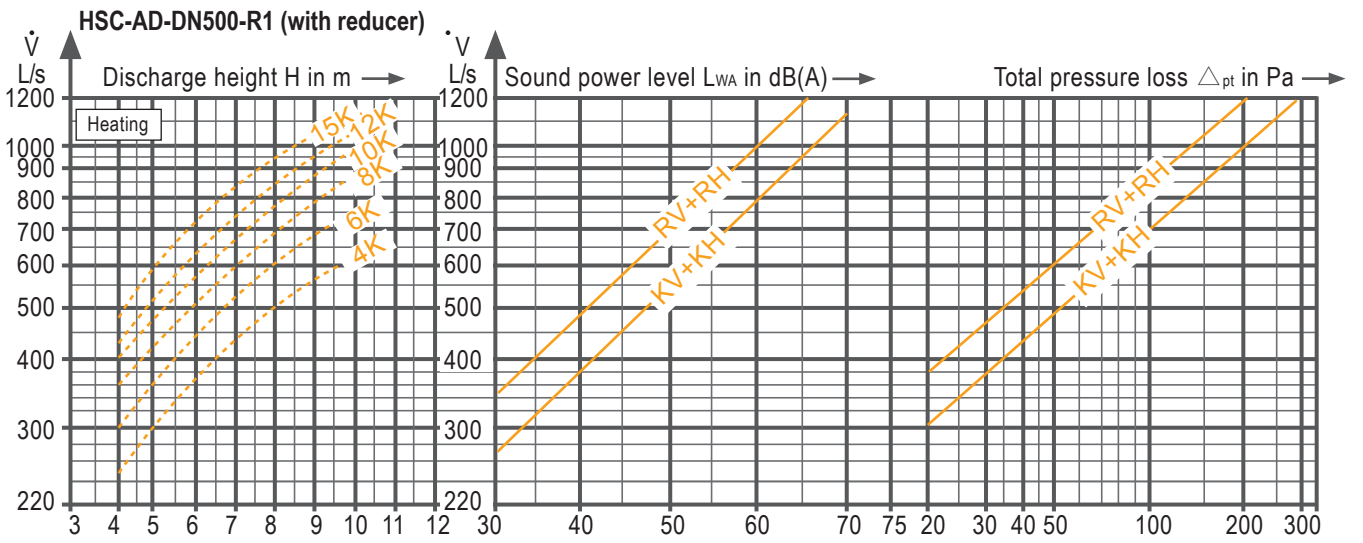
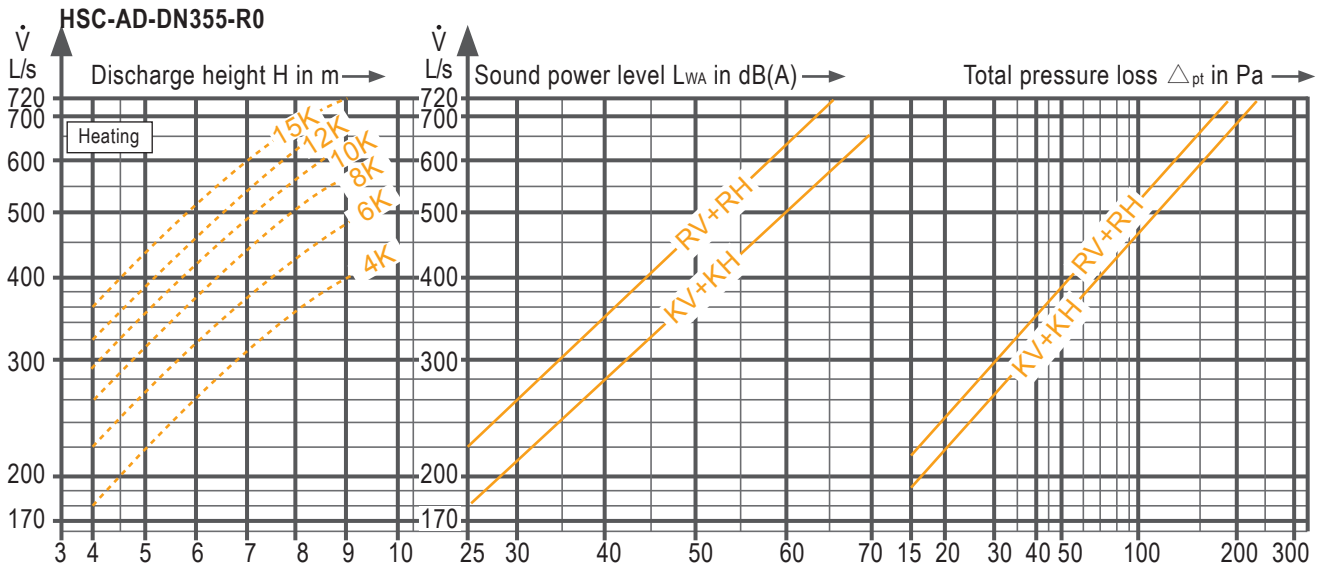

Notes:

R = Round duct connection
K = Connection box

H = Horizontal discharge
V = Vertical discharge

Without acoustic lining the sound power level of the connection box is up to 2 dB(A) higher.

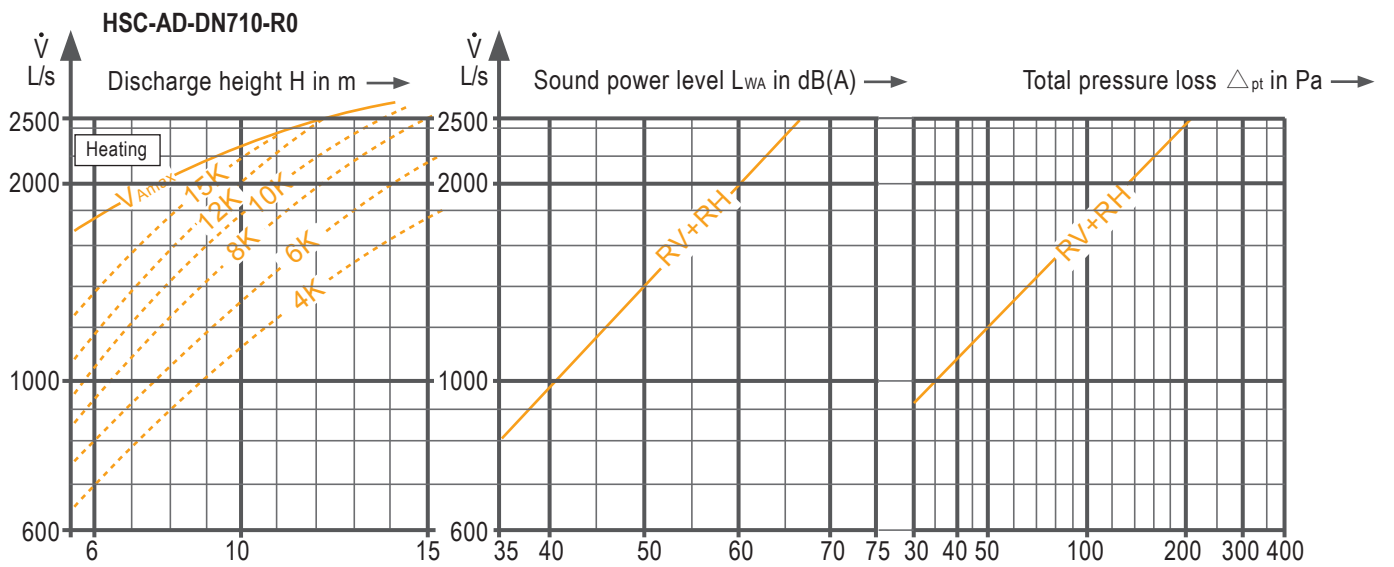
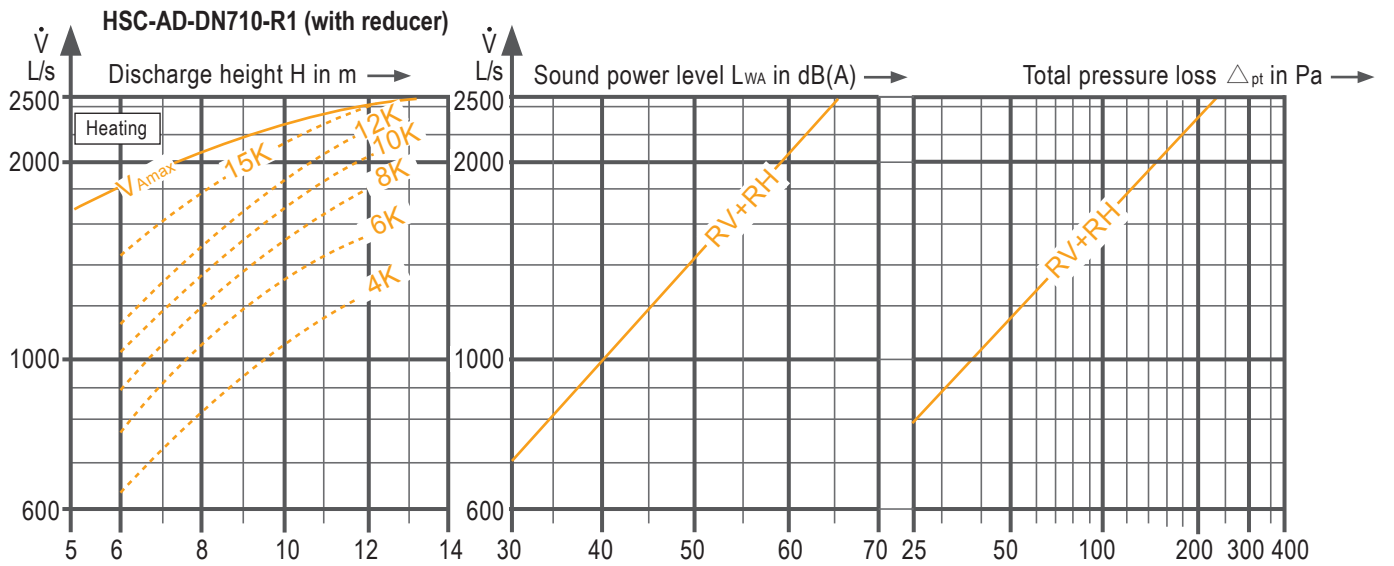

Notes:

- R = Round duct connection
- H = Horizontal discharge
- V = Vertical discharge

Without acoustic lining the sound power level of the connection box is up to 2 dB(A) higher.

Air Diffusion Performance Index (ADPI)

The Air Diffusion Performance Index (ADPI) is a single number that rates the air diffusion performance of a system of diffusers operating in a space. ADPI is affected by such factors as diffuser type and location, airflow rates, heat loads and location, space geometry, etc. To determine ADPI, air velocity and air temperature measurements are made at four different heights at a multitude of locations throughout the occupied zone in accordance with ASHRAE Standard 113. For each measurement point, ADPI evaluates the combined effect of local velocity and temperature deviation from average room temperature to establish whether the threat of draught or stagnation exists at that point. The temperature deviation and air velocity effects are additive, so that an increased threat of draught exists

at points where the air velocity is high and the local temperature is cooler than average; similarly, an increased threat of stagnation exists at points where the air velocity is low and the local temperature is higher than average. The percentage of points that pass the ADPI test (i.e. do not fail due to draught or stagnation) determines the ADPI percentage attained.

According to ASHRAE, for an office environment in cooling mode, the design goal should be an ADPI of 80%. To ensure enhanced conditions of thermal comfort, SMARTEMP diffuser spacing nomograms are based on satisfying an even more stringent ADPI of 90%.

FEATURES

- Diffuse airflow from swirl discharge with adjustable horizontal-to-vertical discharge direction for high thermal comfort from elevated discharge heights.
- 20 off-set radial vanes flush with horizontal diffuser face.
- Diffuser face may be square (up to neck size DN500 only) or circular.
- For installation substantially flush with suspended false ceiling or freely suspended.
- Vanes with cambered leading edges reduce noise and pressure drop.
- Geometrically twisted helical vane tips for increased downward discharge penetration and stable discharge patterns at reduced airflow rates.
- Internal adjustable guide ring with 20 geometrically twisted guide vanes for constant pressure discharge direction adjustment.
- Available in 4 neck sizes: DN250; DN355; DN500; DN710.
- Each neck size available with reducer and reduced guide ring to decrease airflow by approximately 30%.
- Discharge height: 2.5 m to 15 m.
- Minimum cooling (horizontal discharge): $\Delta T_{\text{supply-room}} = -13 \text{ K}$.
- Maximum heating (downward discharge): $\Delta T_{\text{supply-room}} = +15 \text{ K}$, dependent upon airflow rate and discharge height.
- Diffuser made of powder coated sheet-metal.
- Connection to duct or connection box via two threaded rod fasteners accessible through the diffuser face.
- Optional internally insulated sheet-metal side-entry connection boxes available suitable for fastening to twin threaded rods.
- Standard configuration without control module, to provide manual discharge direction adjustment only.
- Control module optionally available with:
 - Electrical actuator kit (24 V supply, with 3-point for 2-position control or 2-10 V for modulating control); or
 - Thermal element kit (with adjustable bias); or
 - No kit, for manual adjustment.

ORDER DETAILS

HSC-AD-DN____-____-R____-____-____

SURFACE FINISH:

- 9003* = Face powder coated to RAL 9003 (Signal White).
- 9005* = Face powder coated to RAL 9005 (Jet Black).
- 9006* = Face powder coated to RAL 9006 (Aluminium).
- _____ = Face powder coated to RAL ____ .

ADJUSTMENT:

- M* = Manual adjustment only.

DN250-DN500:

- CE1 = With base module and electric actuator 24V, 2-10V.
- CE2 = With base module and electric actuator 24V, 3-pt (2-position).
- CT____ = With base module and thermal actuator set to _____ (20°C - 35°C, default 30°C).

DN710:

- E3 = With electric actuator 24V, 2-10V.
- T____ = With thermal actuator set to _____ (20°C - 35°C, default 30°C). **AVAILABLE IN 2018.**

REDUCER:

- 0* = No reducer for high airflows.
- 1 = Reducer for reduced airflows.

FACE SHAPE:

- C* = Circular face with flush contact edge (4 mm / 30°) for closed false ceilings:
 - Ø 375 mm* for size DN250;
 - Ø 530 mm* for size DN355;
 - Ø 750 mm* for size DN500;
 - Ø 1000 mm* for size DN710.
- S = Square face with 90° turn-up for coffered ceilings (up to size DN500 only):
 - □ 345 mm* for size DN250;
 - □ 595 mm* (□ 445 mm to □ 603 mm available) for size DN355;
 - □ 595 mm* to □ 603 mm for size DN500.

NOMINAL DIAMETER:

- DN250 = Nominal neck diameter 250 mm.
- DN355 = Nominal neck diameter 355 mm.
- DN500 = Nominal neck diameter 500 mm.
- DN710 = Nominal neck diameter 710 mm.

MODEL:

- Helical Swirl Ceiling - Adjustable Direction

Note:

* Standard, if no type code entered.
Products supplied may differ slightly from those described in this technical brochure due to on-going product development.

TENDER TEXT

Furnish and install SMARTEMP® Adjustable Helical Swirl Diffusers, type HSC-AD, to provide diffuse airflow with adjustable horizontal-to-vertical discharge direction for high thermal comfort from elevated discharge heights. Each diffuser is to be made of powder coated steel and shall include 20 off-set radial vanes flush with the horizontal diffuser face. The diffuser face is to be square (up to neck size DN500 only) or circular, as specified. The diffuser is to be installed substantially flush with the suspended false ceiling or freely suspended, as specified.

Swirl vanes are to include cambered leading edges for reduced noise and pressure drop, and the helical swirl vane tips are each to incorporate a geometric twist for increased downward discharge penetration and reduced minimum airflow rates. An internal adjustable guide ring with 20 geometrically twisted guide vanes is to provide constant pressure discharge direction adjustment.

The guide ring is to be adjusted manually, electrically or thermally, as specified and in accordance with SMARTEMP guidelines. The latter two each attach as a kit to an included control module, which is optionally available for manual adjustment. Diffuser neck size is to be DN250, DN355, DN500 or DN710, as required. The diffuser is to incorporate the optional reducer and reduced guide ring, where appropriate. Diffuser discharge height of 2.5 to 15 m to be in accordance with SMARTEMP's recommendations for the duty required.

Cooling with horizontal discharge direction to be at no less than $\Delta T_{\text{supply-room}} = -13 \text{ K}$. For heating applications, provide downward discharge and control maximum $\Delta T_{\text{supply-room}}$ not to exceed the maximum permissible heating temperature differential prescribed by SMARTEMP for the selected diffuser, airflow rate and discharge height.

Where specified, each diffuser is to be connected to a side-entry sheet-metal connections box, internally insulated where indicated, fabricated in accordance with SMARTEMP's recommendations. Alternatively, each diffuser is to be connected to a vertical duct of internal diameter equal to the diffuser DN size and at least one duct diameter in length.

SMARTEMP[®]
IN COMFORT